



1 COCHRANE AVE. PENNSBORO, WV 26415 PH.  
800-426-2249

**STORMBREAKER PLUS 300VL  
IMPACT RESISTANT VINYL  
CASEMENT**

ALL MODELS ARE VIEWED FROM THE EXTERIOR

REV. #	REVISIONS:	REVISED BY:	DATE:
1	REVISED PER 2010 FLORIDA BUILDING CODE	C.P.	01-30-12
2	UPDATED ANCHORAGE, HARDWARE	L.T.	12-09-14
3	REMOVED TRIPLE CASEMENT FROM OFFERING	LMH	10-05-17
4	ADDED SIZE - EC 18-056 & GP 18-021.	LMH	6-28-18

**GENERAL NOTES:**

1. THIS PRODUCT IS DESIGNED TO COMPLY WITH THE 6TH ED. (2017) FLORIDA BUILDING CODE, INCLUDING THE HIGH VELOCITY HURRICANE ZONE, AND WAS TESTED USING METHODS TAS 201, TAS 202, AND TAS 203. GLAZING AS INDICATED HEREIN COMPLIES WITH ASTM E 1300-04e01/09. THIS PRODUCT IS LARGE MISSILE IMPACT RATED AND DOES NOT REQUIRE THE USE OF IMPACT PROTECTIVE DEVICES OR SHUTTERS.
2. ANCHOR TYPE, SIZE, SPACING, AND EMBEDMENT SHALL BE AS SPECIFIED IN THESE DRAWINGS, USING ONLY MIAMI-DADE COUNTY APPROVED CORROSION-RESISTANT FASTENERS OR ITW TAPCON FASTENERS. ALL FASTENERS PENETRATING INTO PRESSURE TREATED WOOD SHALL BE CAPABLE OF PREVENTING CORROSION DUE TO REACTION WITH PRESSURE TREATMENT CHEMICALS. SHIMS MUST BE USED WHEN GAP OF GREATER THAN 1/16" BETWEEN FRAME AND OPENING IS PRESENT AT THE ANCHOR LOCATION. MAX. SHIM STACK = 1/4". HIGH QUALITY SILICONE CAULK SHALL BE USED BY INSTALLER AROUND ENTIRE WINDOW PERIMETER, INSIDE AND OUT.
3. DISSIMILAR MATERIALS THAT COME INTO CONTACT SHALL BE COATED OR OTHERWISE PROTECTED PER FBC TO PREVENT GALVANIC REACTIONS. WOOD BUCKS, IF USED, SHALL BE PRESSURE TREATED, WITH EITHER A TREATMENT OR COATING COMPATIBLE WITH THE MATERIALS OF THIS DOOR.
4. ANCHOR EMBEDMENT TO SUBSTRATE SHALL BE BEYOND WALL DRESSING OR STUCCO. FOR CONCRETE/CMU OPENINGS, EMBEDMENT SHALL BE BEYOND WOOD BUCKS, IF USED, AND INTO SUBSTRATE. INSTALLATIONS TO SOLID CONCRETE OR GROUT-FILLED CMU MAY INCLUDE BUT DO NOT REQUIRE 1X WOOD BUCKS BETWEEN PRODUCT AND SUBSTRATE. INSTALLATIONS TO HOLLOW CMU REQUIRE THE USE OF 1X BUCKS BETWEEN PRODUCT AND SUBSTRATE.
5. WOOD OR MASONRY OPENINGS, BUCKS, AND BUCK FASTENERS, BY OTHERS, SHALL BE PROPERLY DESIGNED AND INSTALLED TO TRANSFER WIND LOADS TO THE STRUCTURE. SUBSTRATES SHALL MEET THE MINIMUM STRENGTH REQUIREMENTS AS SHOWN IN THESE DRAWINGS. CONCRETE OR MASONRY SUBSTRATES SHALL NOT BE CRACKED.
6. SEALING AND FLASHING STRATEGIES FOR OVERALL WATER PENETRATION RESISTANCE OF THE INSTALLED PRODUCT ARE THE RESPONSIBILITY OF OTHERS.
7. A WIND LOAD DURATION FACTOR CD = 1.6 WAS USED FOR THE ANALYSIS OF WOOD SCREWS ONLY.
8. FOR INSTALLATION TO METAL SUBSTRATES, ANCHORS SHALL BE LONG ENOUGH TO BE FULLY THREADED THROUGH THE METAL THICKNESS WITH AN ADDITIONAL 3/16" MIN. OF THREADS BEYOND

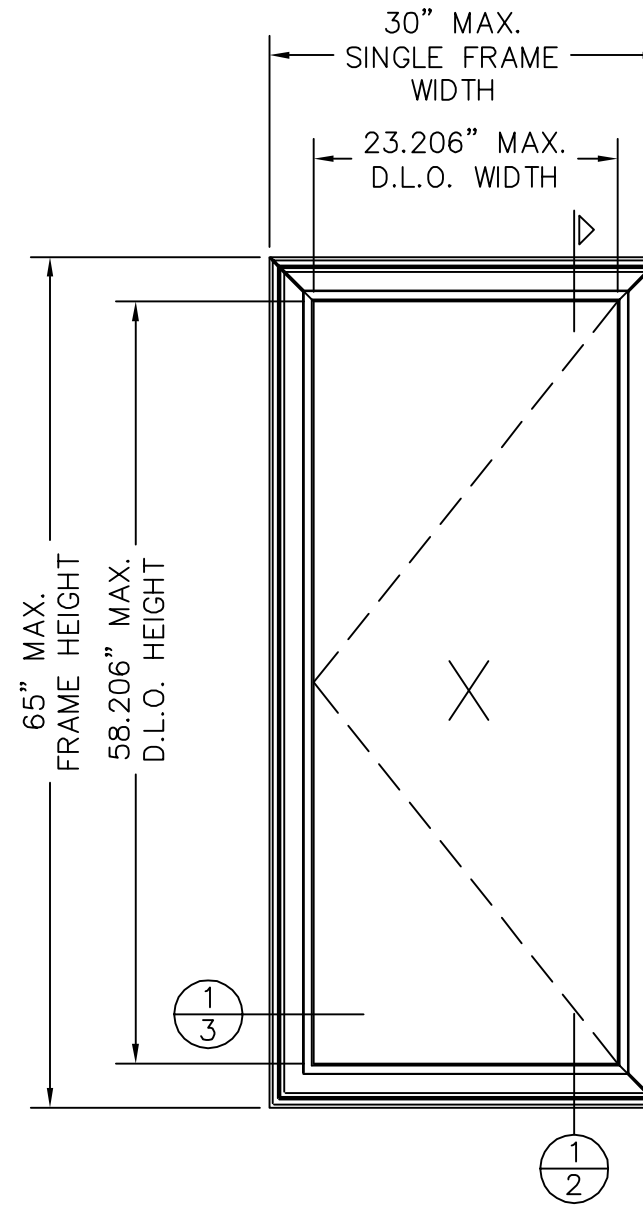

**LARGE MISSILE IMPACT**

**30" X 65" CASEMENT  
STORMBREAKER PLUS**

**DESIGN PRESSURE RATING  
+50.0 PSF -50.0 PSF**

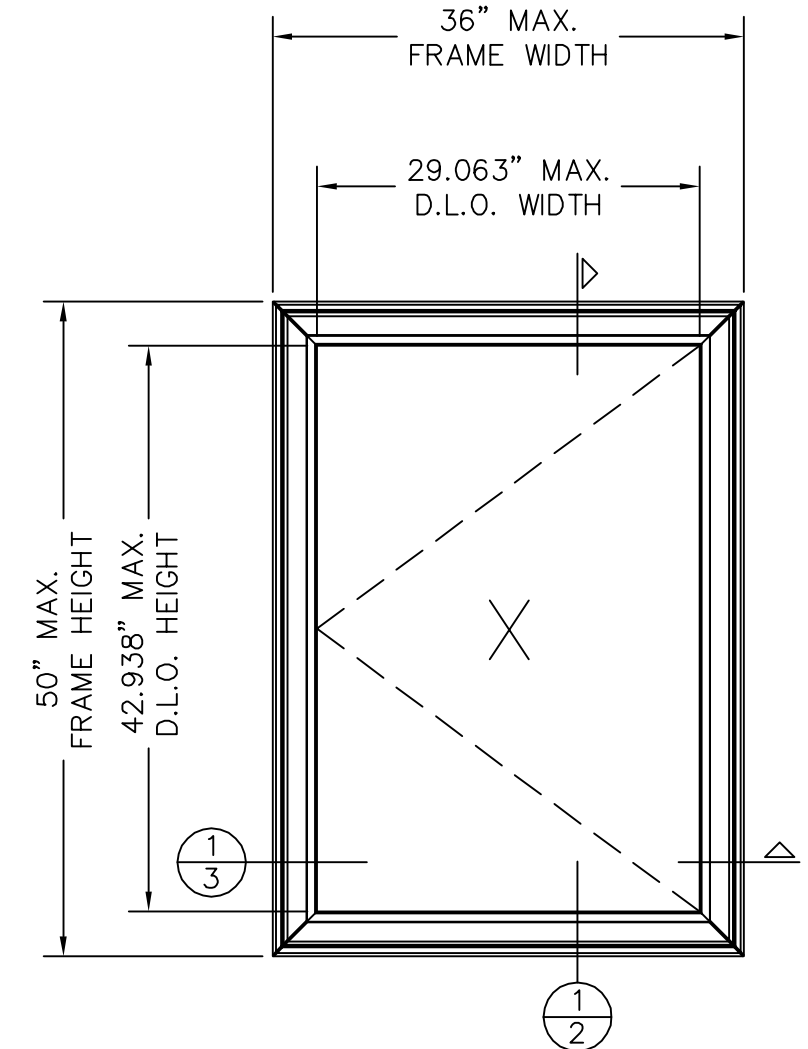

**LARGE MISSILE IMPACT**

**36" X 50" CASEMENT  
STORMBREAKER PLUS**

**DESIGN PRESSURE RATING  
+55.0 PSF -55.0 PSF**

TABLE OF CONTENTS	
SHEET #	DESCRIPTION
1	GEN. NOTES, TYPICAL ELEVATION, TABLE OF CONTENTS
2	VERTICAL CROSS SECTIONS
3	HORIZONTAL CROSS SECTIONS
4	ANCHORING LOCATIONS
5	COMPONENTS, BILL OF MATERIALS, GLAZING DETAILS

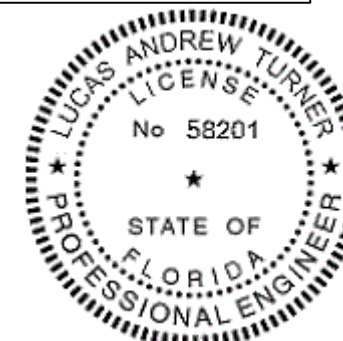

7/3/2018  
LUCAS A. TURNER, P.E.  
FL PE # 58201  
TURNER ENGINEERING &  
CONSULTING, INC.  
(COA # 29779)  
2428 OLD NATCHEZ TRACE  
TRAIL, CAMDEN, TN 38320  
PH. 941-380-1574

	SIZE: DRAWING NO.:	REV.:
	B DA0007	4
	DRAWN BY: DATE:	10/13/08
1 Cochrane Avenue Pennsboro, WV 26415	CHECKED BY: DATE:	
SCALE: FIT	SHEET: 1 of 5	APPR'VD BY: DATE: C.P. 01/30/12
SERIES:	STORMBREAKER PLUS 300VL CASEMENT	
TITLE:	GENERAL NOTES & TYPICAL ELEVATIONS	

REV. #	REVISIONS:	REVISED BY:	DATE:
1	REVISED PER 2010 FLORIDA BUILDING CODE	C.P.	01-30-12
2	UPDATED ANCHORAGE, HARDWARE	L.T.	12-09-14
3	REMOVED TRIPLE CASEMENT FROM OFFERING	LMH	10-05-17
4	ADDED SIZE - EC 18-056 & GP 18-021.	LMH	6-28-18

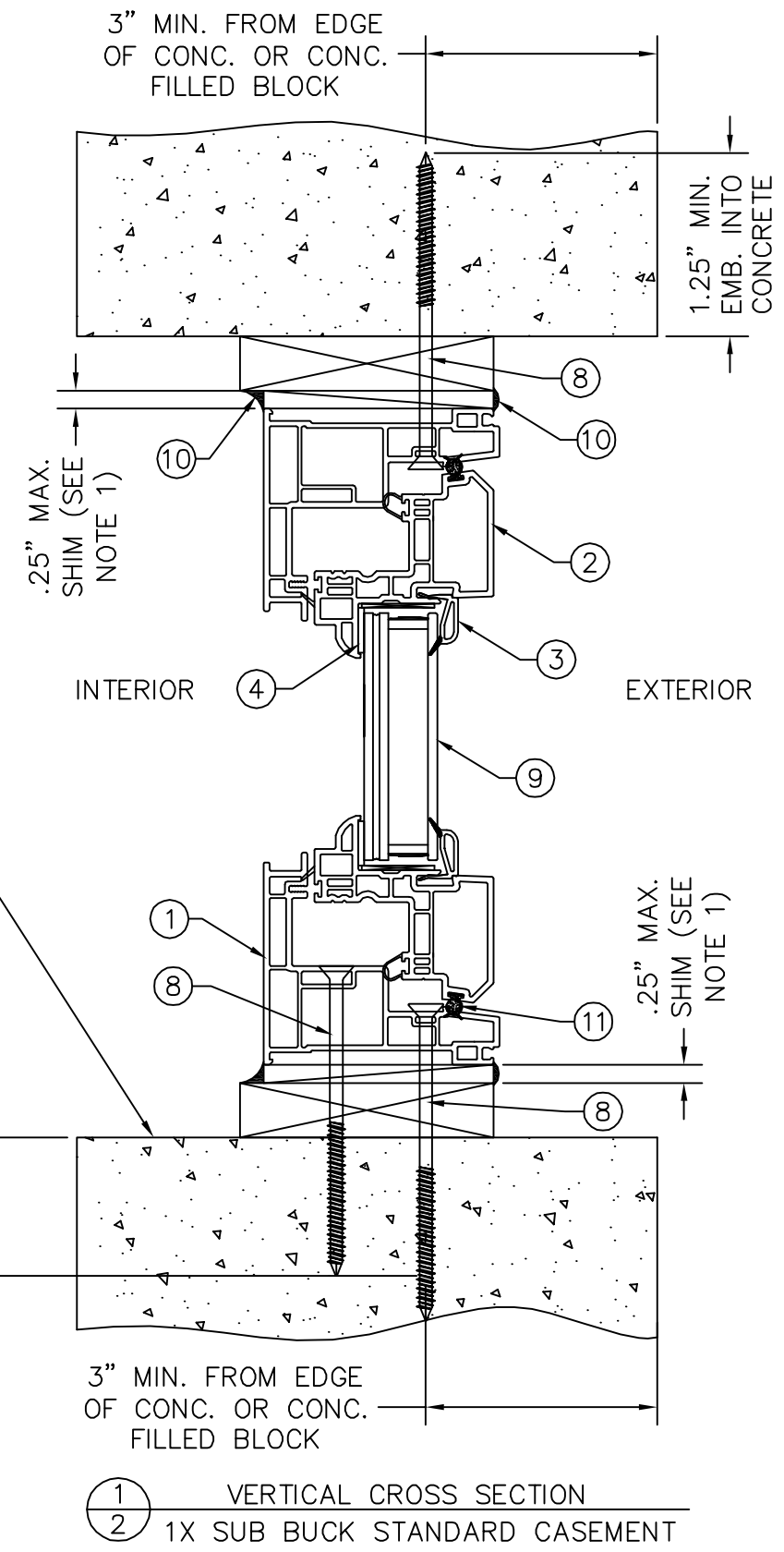
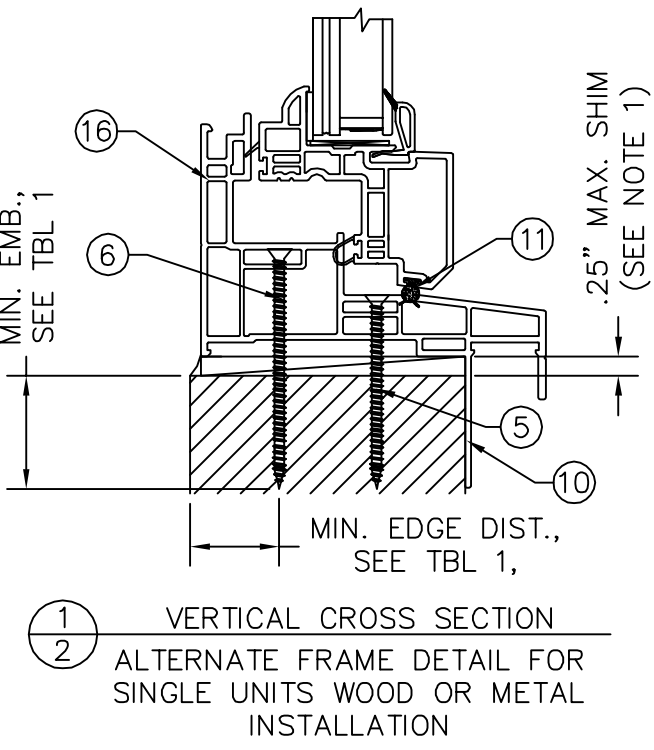
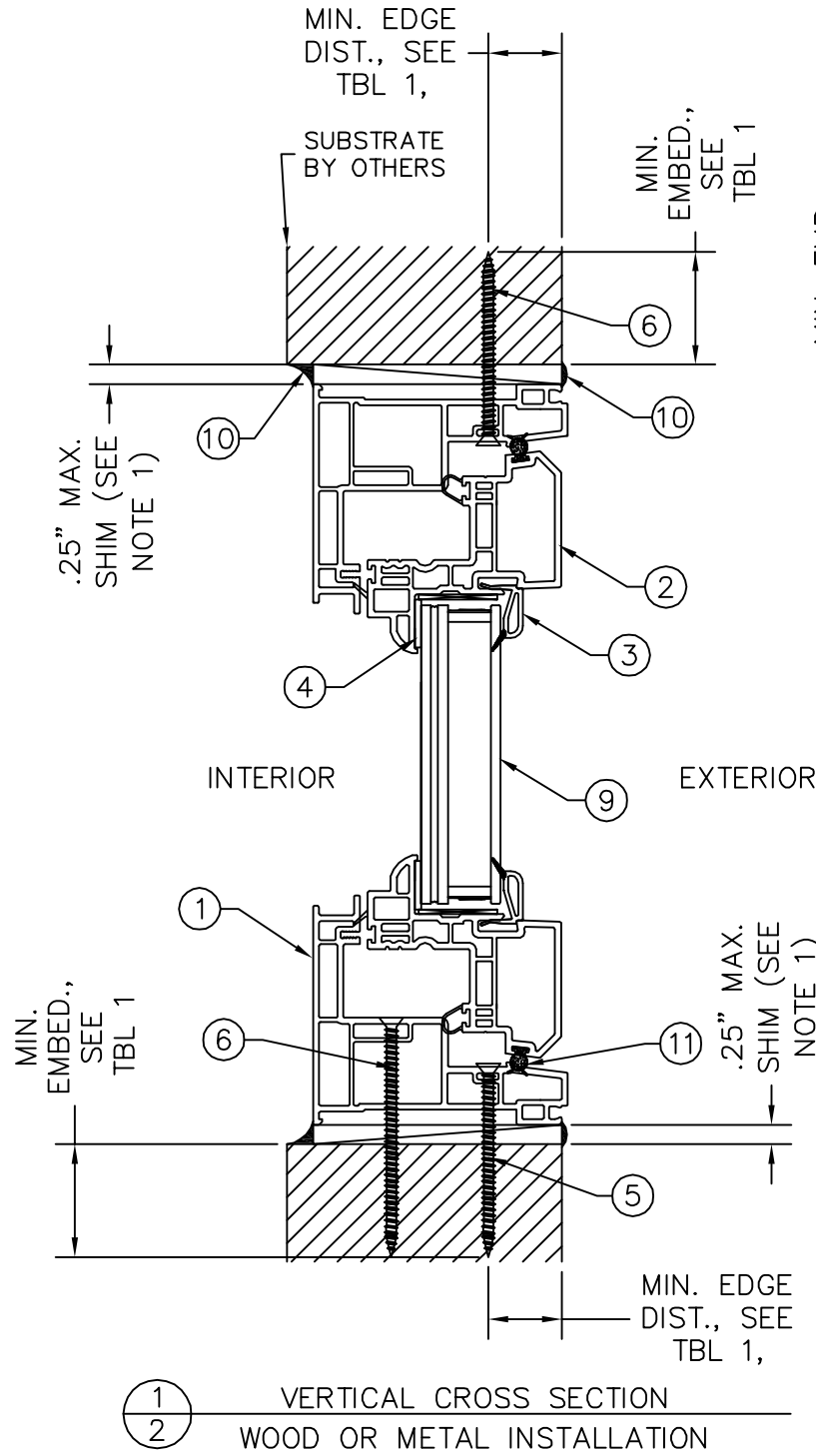

SEE ANCHOR LOCATION  
ELEVATIONS SHEET 4

- NOTES:
1. THE SHIM IS REQUIRED TO BE A "RIGID/STIFF" MATERIAL THAT COMPLIES WITH THE REQUIREMENTS OF THE FLORIDA BUILDING CODE INCLUDING HVHZ.
  2. CORROSION RESISTANT FASTENERS AND MATERIALS THAT COME INTO CONTACT WITH OTHER DISSIMILAR MATERIALS SHALL MEET THE REQUIREMENTS OF THE FLORIDA BUILDING CODE.
  3. APPLY CAULK AROUND SCREWS AT THE SILL ONLY.
  4. REPLACE SECOND AND BOTTOM HINGE TRACK SCREWS WITH INSTALLATION SCREWS, ITEM NUMBER 6 (WOOD) OR 8 (CONC.)
  5. REPLACE ONE OPERATOR BRACKET SCREW WITH INSTALLATION SCREWS, ITEM NUMBER 6 (WOOD) OR 8 (CONC.)

TABLE 1: INSTALLATION FASTENERS

ID	SUBSTRATE TYPE	ANCHOR TYPE	MIN. EMBED	MIN. EDGE DIST.
A	CONCRETE (2 KSI MIN.) THRU WINDOW	3/16" ITW TAPCON	1-1/4"	3"
B	HOLLOW OR GROUT-FILLED CMU (ASTM C90)	3/16" ITW TAPCON	1-1/4"	3"
C	2X MIN. SOUTHERN PINE WOOD (G=0.55)	3/16" ITW TAPCON	1-3/8"	3/4"
D	2X MIN. SOUTHERN PINE WOOD (G=0.55)	#10 WOOD SCREW	1-3/8"	3/4"
E	1/8" ALUM. 6063-T5 MIN. OR 1/8" STEEL 36 KSI MIN.	#10 GRADE 5 SELF-TAPPING/DRILLING SCREW	SEE NOTE 8, SHEET 1	1/2"

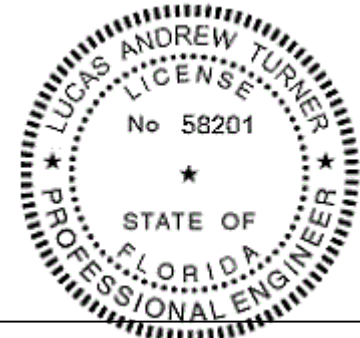

7/3/2018  
LUCAS A. TURNER, P.E.  
FL PE # 58201  
TURNER ENGINEERING & CONSULTING, INC.  
(COA # 29779)  
2428 OLD NATCHEZ TRACE TRAIL, CAMDEN, TN 38320  
PH. 941-380-1574

<p>1 Cochrane Avenue Pennsboro, WV 26415</p>	SIZE: DRAWING NO.:	REV.:
	B DA0007	4
	DRAWN BY: DATE:	
	GLS 10/13/08	CHECKED BY: DATE:
SCALE: FIT	SHEET: 2 of 5	APPR'VD BY: DATE:
	C.P.	C.P. 01/30/12
SERIES:	STORMBREAKER PLUS 300VL CASEMENT	
TITLE:	VERTICAL CROSS SECTIONS	

REV. #	REVISIONS:	REVISED BY:	DATE:
1	REVISED PER 2010 FLORIDA BUILDING CODE	C.P.	01-30-12
2	UPDATED ANCHORAGE, HARDWARE	L.T.	12-09-14
3	REMOVED TRIPLE CASEMENT FROM OFFERING	LMH	10-05-17
4	ADDED SIZE -- EC 18-056 & GP 18-021.	LMH	6-28-18

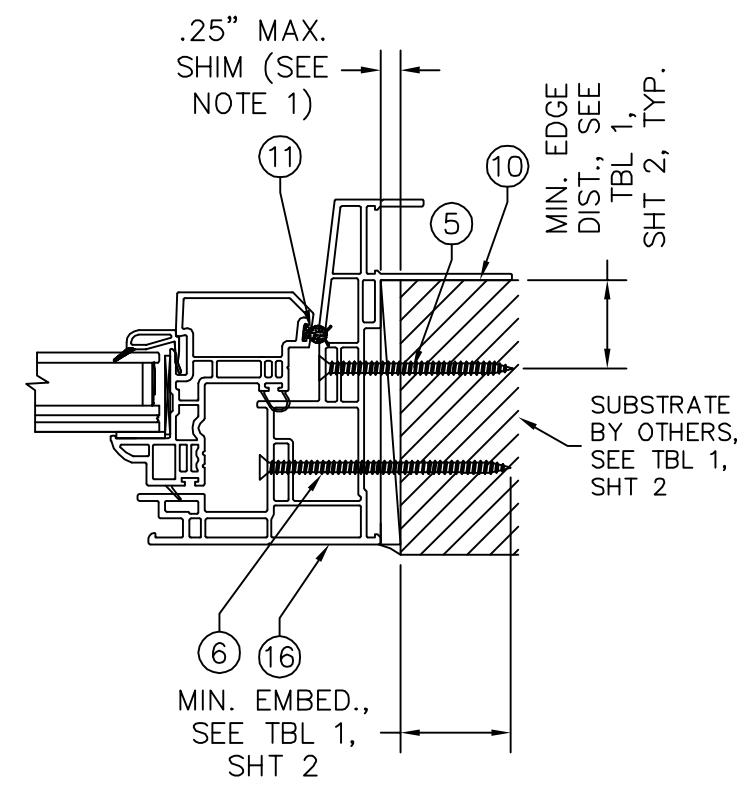
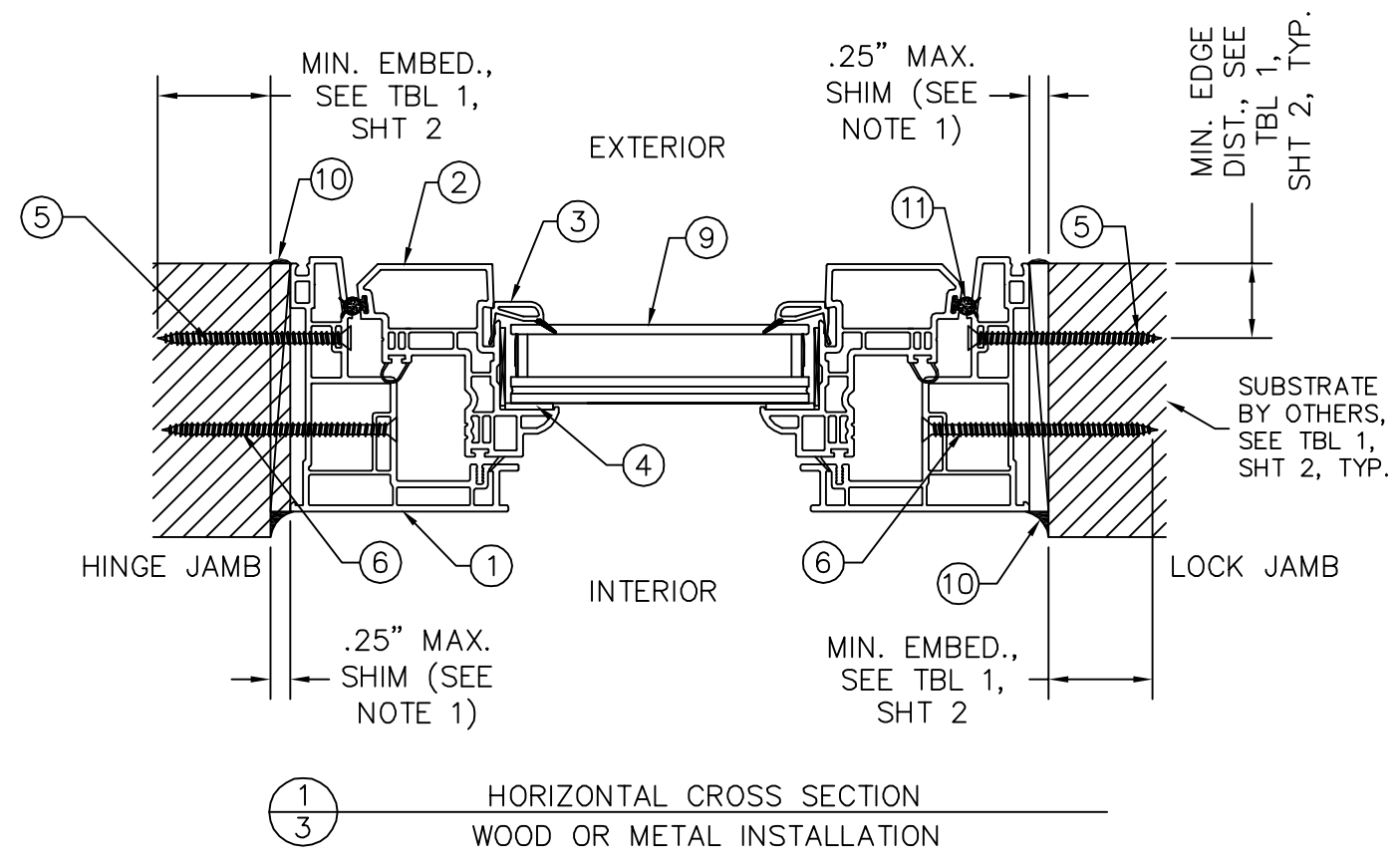

SEE ANCHOR LOCATION  
ELEVATIONS SHEET 4

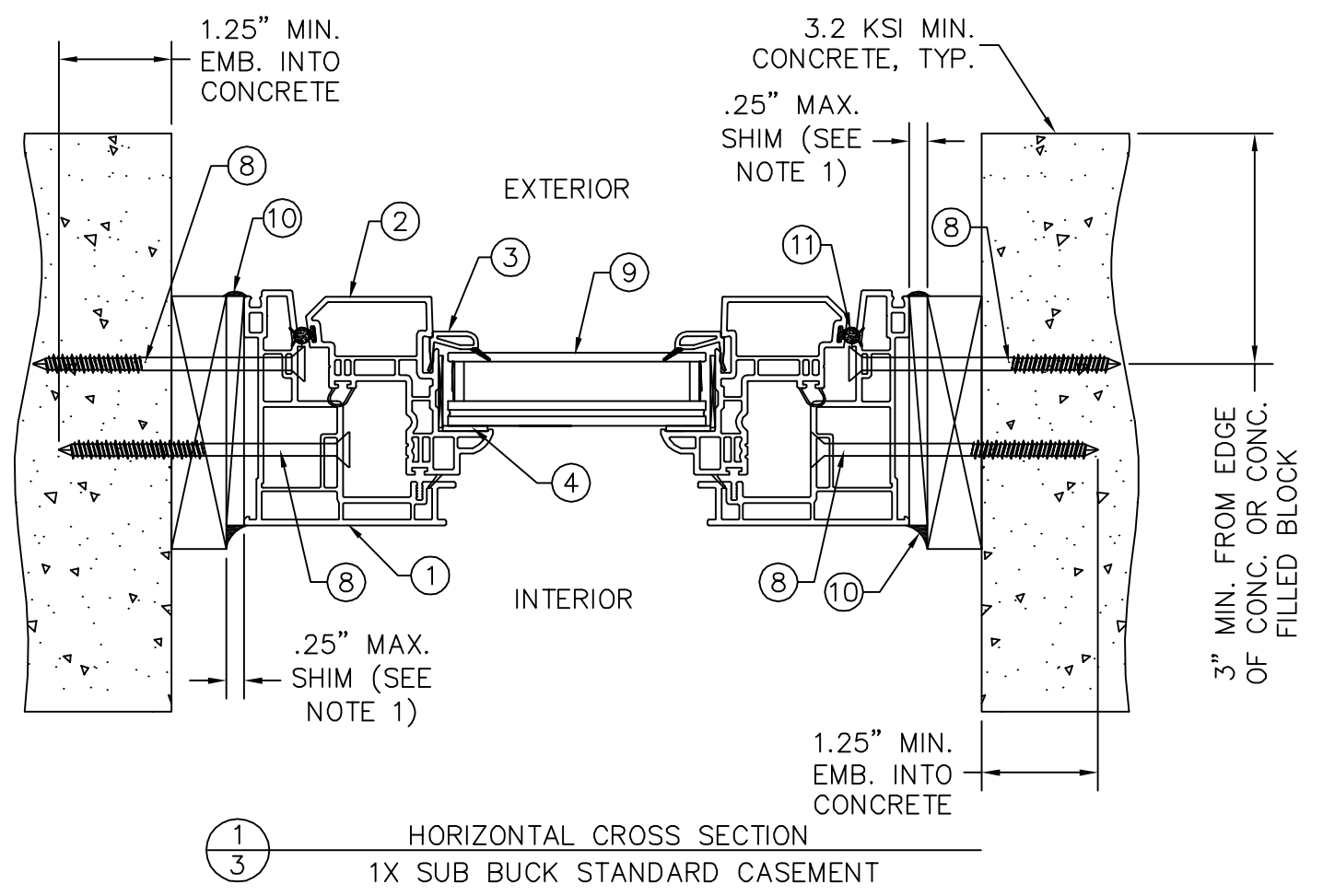

- NOTES:
1. THE SHIM IS REQUIRED TO BE A "RIGID/STIFF" MATERIAL THAT COMPLIES WITH THE REQUIREMENTS OF THE FLORIDA BUILDING CODE INCLUDING HVHZ.
  2. CORROSION RESISTANT FASTENERS AND MATERIALS THAT COME INTO CONTACT WITH DISSIMILAR MATERIALS SHALL MEET THE REQUIREMENTS OF THE FLORIDA BUILDING CODE.
  3. REPLACE ONE SCREW IN EACH IMPACT SNUBBER WITH INSTALLATION SCREWS, ITEM NUMBER 5 (WOOD) OR 8 (CONC.)
  4. REPLACE ONE SCREW IN EACH TIE BAR GUIDE WITH AN INSTALLATION SCREW, ITEM NUMBER 6 (WOOD) OR 8 (CONC.)

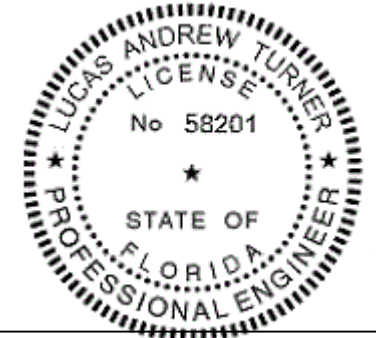

ZZ  
7/3/2018  
LUCAS A. TURNER, P.E.  
FL PE # 58201  
TURNER ENGINEERING & CONSULTING, INC.  
(COA # 29779)  
2428 OLD NATCHEZ TRACE TRAIL, CAMDEN, TN 38320  
PH. 941-380-1574

	SIZE: DRAWING NO.:	REV.:
	B DA0007	4
1 Cochrane Avenue Pennsboro, WV 26415	DRAWN BY: DATE:	CHECKED BY: DATE:
	GLS 10/13/08	
SCALE: FIT	SHEET: 3 of 5	APPR'VD BY: DATE:
		C.P. 01/30/12
SERIES: STORMBREAKER PLUS 300VL CASEMENT		
TITLE: HORIZONTAL CROSS SECTIONS		

REV. #	REVISIONS:	REVISED BY:	DATE:
1	REVISED PER 2010 FLORIDA BUILDING CODE	C.P.	01-30-12
2	UPDATED ANCHORAGE, HARDWARE	L.T.	12-09-14
3	REMOVED TRIPLE CASEMENT FROM OFFERING	LMH	10-05-17
4	ADDED SIZE -- EC 18-056 & GP 18-021.	LMH	6-28-18

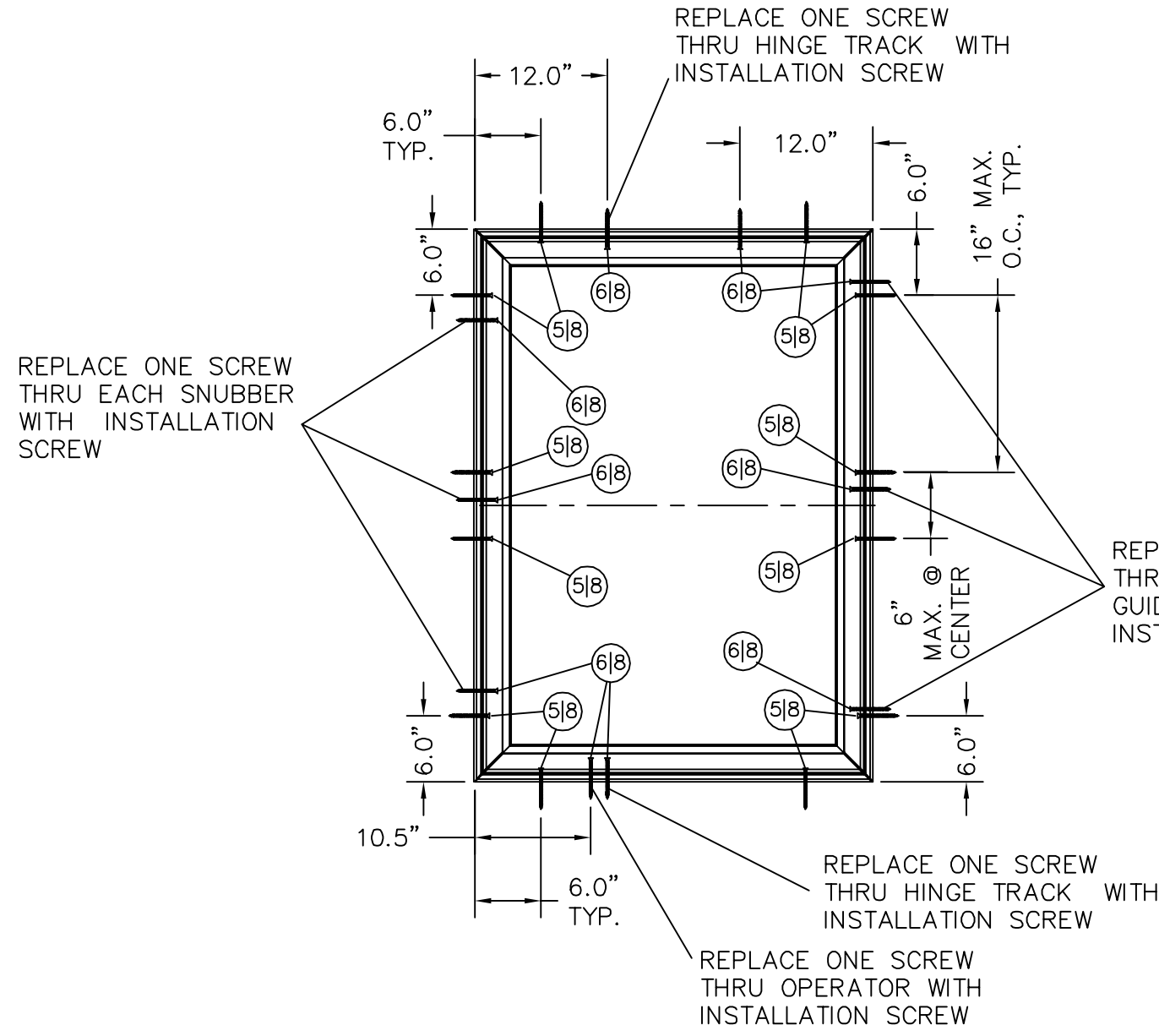

**36" X 50" CASEMENT**  
 2X WOOD BUCK ANCHORING LOCATIONS  
 1X WOOD BUCK OVER MASONRY ANCHORING LOCATIONS

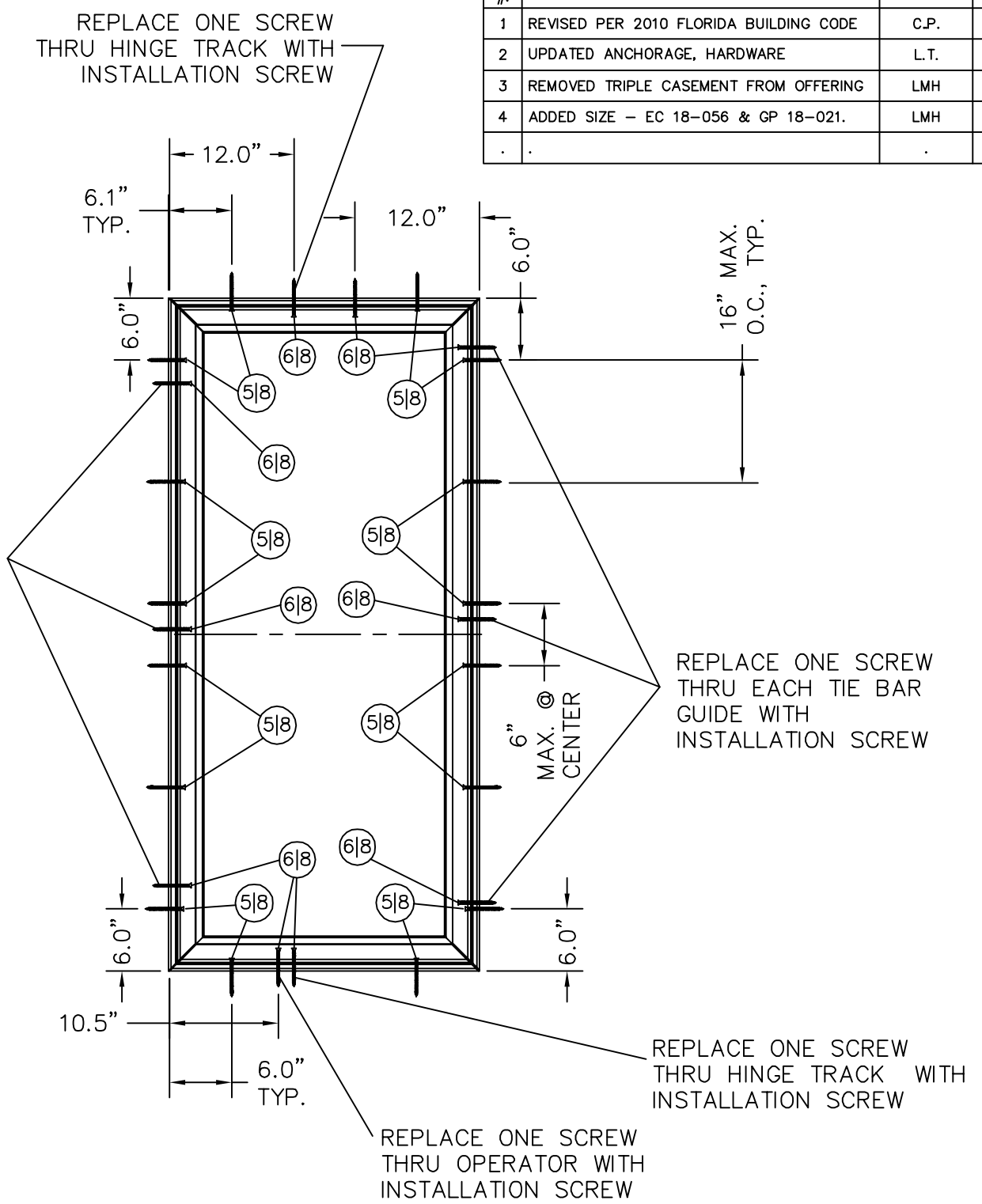

**30" X 65" CASEMENT**  
 2X WOOD BUCK ANCHORING LOCATIONS  
 1X WOOD BUCK OVER MASONRY ANCHORING LOCATIONS

**NOTE:**  
 WHEN ANCHORING CASEMENT WINDOWS TO A 2X BUCK, USE ITEMS 5 & 6 (#10 X 2 1/2" & #10 X 3" PH FH WOOD SCREWS) WITH 3/4" MINIMUM EDGE DISTANCE AND 1 3/8" MINIMUM EMBEDMENT INTO WOOD.  
 WHEN ANCHORING CASEMENT WINDOWS TO A 1X BUCK AND CONCRETE/BLOCK USE ITEM 8 (3/16" X 3 1/4" ITW TAPCONS) WITH EDGE DISTANCE GREATER THAN OR EQUAL TO 3" WITH 1 1/4" MINIMUM EMBEDMENT INTO MASONRY.

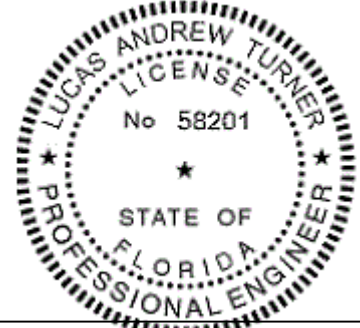

*LT*  
 7/3/2018  
 LUCAS A. TURNER, P.E.  
 FL PE # 58201  
 TURNER ENGINEERING & CONSULTING, INC.  
 (COA # 29779)  
 2428 OLD NATCHEZ TRACE TRAIL, CAMDEN, TN 38320  
 PH. 941-380-1574

	SIZE: DRAWING NO.:	REV.:
	B DA0007	4
1 Cochrane Avenue Pennsboro, WV 26415	DRAWN BY:	DATE:
	GLS	10/13/08
SCALE: FIT	CHECKED BY:	DATE:
SHEET: 4 of 5	APPR'VD BY:	DATE:
	C.P.	01/30/12
SERIES: STORMBREAKER PLUS 300VL CASEMENT		
TITLE: ANCHORING LOCATIONS		

BILL OF MATERIALS		
ITEM #	DESCRIPTION	MATERIAL
1	EXTRUDED CASEMENT FRAME	RIGID VINYL
2	EXTRUDED CASEMENT SASH	RIGID VINYL
3	EXTRUDED GLAZING BEAD	RIGID VINYL
4	GLAZING COMPOUND - PECORA 896 HIS	SILICONE
5	#10 X 2 1/2" PH FH WOOD SCREW FOR WOOD INSTALL #10 X 2 1/2" SELF-DRILLING SCREW FOR METAL INSTALL	STEEL
6	#10 X 3" PH FH WOOD SCREW FOR WOOD INSTALL #10 X 3" SELF-DRILLING SCREW FOR METAL INSTALL	STEEL
	-----NOT USED-----	
8	3/16"Ø X 3 1/4" I.T.W. TAPCON ANCHOR	STEEL
9	1" INSULATED TEMPERED/ANNEALED IMPACT GLASS WITH .090" SOLUTIA PVB INTERLAYER	-
10	HIGH QUALITY SILICONE CAULK	SILICONE
11	.187 X .300 FOAM-FILLED VINYL BULB	-
	-----NOT USED-----	
	-----NOT USED-----	
	-----NOT USED-----	
	-----NOT USED-----	
16	EXTRUDED CASEMENT FRAME WITH INTEGRAL FLANGE	RIGID VINYL

REV. #	REVISIONS:	REVISED BY:	DATE:
1	REVISED PER 2010 FLORIDA BUILDING CODE	C.P.	01-30-12
2	UPDATED ANCHORAGE, HARDWARE	L.T.	12-09-14
3	REMOVED TRIPLE CASEMENT FROM OFFERING	LMH	10-05-17
4	ADDED SIZE - EC 18-056 & GP 18-021.	LMH	6-28-18

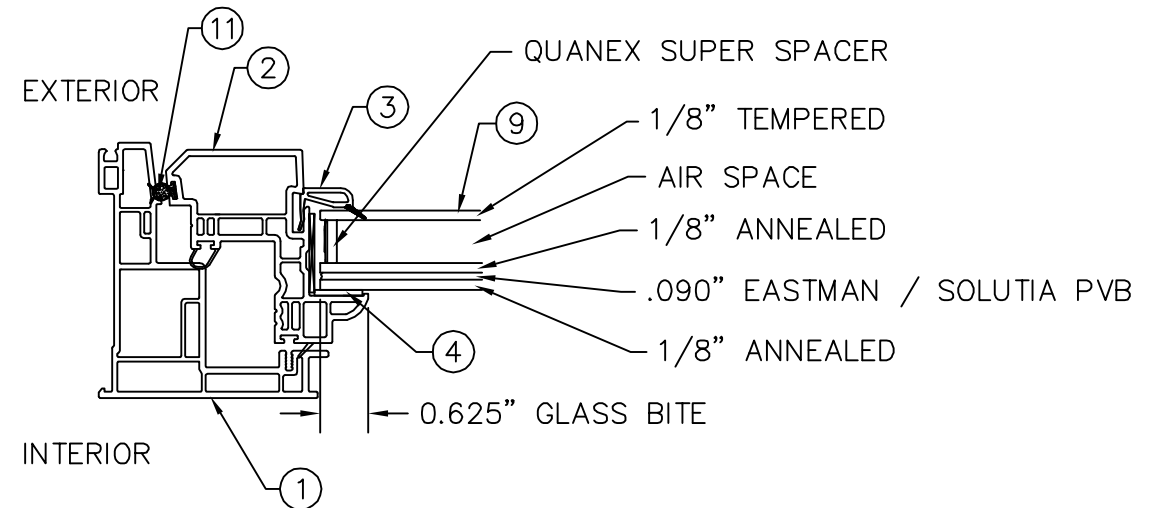

1.0" INSULATED TEMPERED/ANNEALED IMPACT  
RESISTANT GLASS GLAZING DETAIL  
36" X 50" CASEMENT &  
30" X 65" CASEMENT

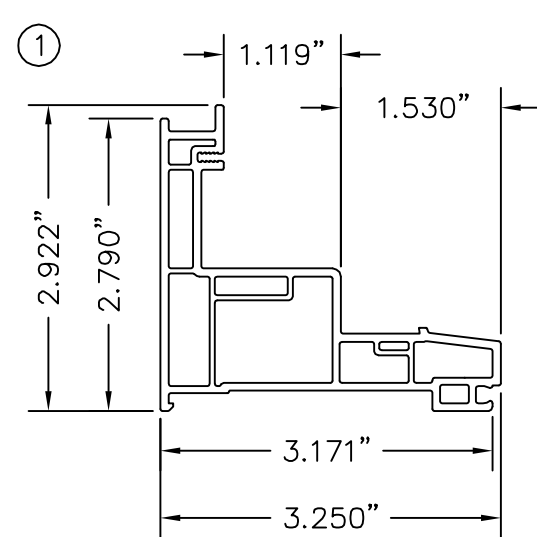

CASEMENT WINDOW FRAME  
0.079" MAX. WALL & 0.060" MIN. WALL

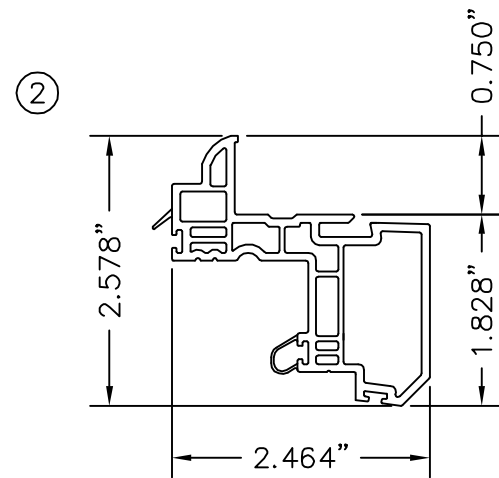

CASEMENT SASH  
0.079" MAX. WALL & 0.059" MIN. WALL

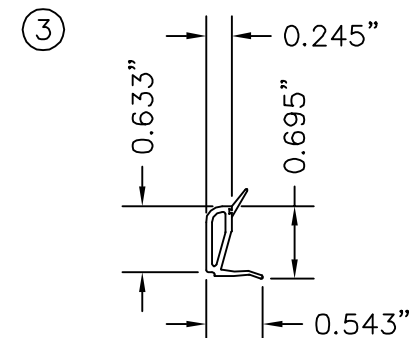

GLAZING BEAD  
BV68

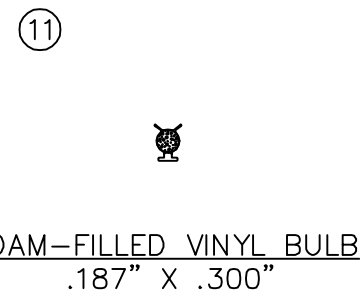

FOAM-FILLED VINYL BULB  
.187" X .300"



27  
7/3/2018  
LUCAS A. TURNER, P.E.  
FL PE # 58201  
TURNER ENGINEERING &  
CONSULTING, INC.  
(COA # 29779)  
2428 OLD NATCHEZ TRACE  
TRAIL, CAMDEN, TN 38320  
PH. 941-380-1574

	SIZE: DRAWING NO.:	REV.:
	B DA0007	4
1 Cochrane Avenue Pennsboro, WV 26415	DRAWN BY:	DATE:
	GLS	10/13/08
SCALE: FIT	CHECKED BY:	DATE:
SERIES: STORMBREAKER PLUS 300VL CASEMENT	APPR'VD BY:	DATE:
	C.P.	01/30/12
TITLE: COMPONENTS, BILL OF MATERIALS & GLAZING DETAILS		